

CRIO Line CP 1 Door and 6 Drawer Refrigerated Counter, 420lt with Splashback (R290)

ITEM # _____

MODEL # _____

NAME # _____

SIS # _____

AIA # _____



721148 (AA3R3ACC)

1-door and 6x1/3-drawer refrigerated counter, -2/+10°C, full AISI 304 (R290), with splashback

Short Form Specification

Item No. _____

AISI 304 stainless steel panels, AISI 304 bottom panel, AISI 304 back panel. Worktop thickness 50mm, fitted with integrated rear splashback h=100mm. Full door and N. 6X1/3 drawers. Built-in refrigeration unit. Operating temperature: -2/+10°C. R290 gas in refrigeration circuit. Supplied with 1 grid for each door compartment

Main Features

- Tropicalized unit (43°C ambient temperature).
- Large digital white-digit display with humidity selection button (3 preset level), internal temperature display and setting, manual activation of defrost cycle and turbo frost cycle (to rapidly cool warm loads).
- Equipped with Airflow system: forced air circulation system for rapid cooling and even temperature distribution within the cell.
- 0mm clearance installation space: tower configuration cooling unit guarantee performance with frontal ventilation only; this unique solution allows installation against the wall or side by side with other appliances, even on the cooling unit side to maximize the use of kitchen space.
- Combination of doors and drawers to suit any configuration needed, with the possibility to change the configuration on site. Right cooling unit available on request.
- Frontal and easy access to all components in the cooling unit.
- Fully compliant HACCP digital control: when temperature exceeds critical limits, acoustic and visual alarms are activated. Up to two months of event are kept in memory.
- Anti-tilt runners accept GN 1/1 containers.
- Self closing stainless steel doors (< 90°).
- Certified safety CE requirements.
- Prearranged to fit RS485 port to facilitate connection to a remote computer and integrated HACCP systems.
- Hot gas automatic evaporation of defrost water.
- Adjustable temperature range from -2 °C to +10 °C to suit meat, fish and dairy storage requirements.
- Mounted on stainless steel feet to give 150 mm (-5/+50 mm) clearance for ease of cleaning the floor.
- Connectivity ready for real time access to connected appliances from remote and data monitoring (requires optional accessory).
- Easy serviceability thanks to the intuitive control panel with remote access via app.
- Integrated RS485 port to facilitate connection to a remote computer and integrated HACCP systems.

Construction

- Extractable cooling unit to facilitate maintenance.
- IP21 protection index.
- Internal dimension of the drawers:
 - models with 2 1/2 drawers: 1st drawer (top drawer) 196x302x521 / 2nd drawer 198x302x521 (HxWxD)
 - models with 3 1/3 drawers: 1st and 2nd drawers (top and central drawer) 99x302x521 / 3rd drawers 103x302x521 (HxWxD)
 - models with 1/3+2/3 drawers: 1st drawer (top drawer) 99x302x521 / 2nd drawer 295x302x521 (HxWxD)

APPROVAL: _____

- Fault code display.
- Interior base with rounded corners, pressed from a single sheet.
- Internal and external doors, front and side panels and removable worktop in AISI 304 Stainless steel.
- Built-in refrigeration unit.
- Ease of cleaning and high hygiene standards thanks to the rounded internal corners, the easily removable runners, grids and air conveyors.
- Internal structure with 15 charging positions (3 cm pitch) available to host GN 1/1 grids, ensuring higher net capacity and a greater storage space.
- Internal dimension of the drawers:
 - models with 2 1/2 drawers: 1st drawer (top drawer) 203x302x521 / 2nd drawer 223x302x521 (HxWxD)
 - models with 3 1/3 drawers: 1st drawer (top drawer) 98x302x521 / 2nd and 3rd drawers 118x302x521 (HxWxD)
 - models with 1/3+2/3 drawers: 1st drawer (top drawer) 98x302x521 / 2nd drawer 333x302x521 (HxWxD)
- Developed and produced in ISO 9001 and ISO 14001 certified factory.

- energy efficiency consumption.
- Fitted with 90 mm thickness of cyclopentane insulation for best insulating performance (thermal conductivity: 0,020 W/m*K) and lowest environmental impact (GWP=3).

Included Accessories

- 1 of Kit 1/1GN gray rilsan grid and 2 side runners for refrigerated counters PNC 881109

Optional Accessories

- 1/1GN gray rilsan grid for refrigerated counters PNC 881107
- 2 side runners for 1/1GN refrigerated counters PNC 881108
- Kit 1/1GN gray rilsan grid and 2 side runners for refrigerated counters PNC 881109
- 1/1GN plastic container, h65mm PNC 881110
- 1/1GN plastic container, h100mm PNC 881111
- 1/1GN plastic container, h150mm PNC 881112
- Worktop for refrigerated Crio Line CP and SB counters - 3 compartments PNC 881125
- Worktop and upstand for refrigerated Crio Line CP and SB counters - 3 compartments PNC 881128
- 2-drawer kit refrigerated counters PNC 881179
- 3x1/3-drawer kit for refrigerated counters PNC 881186
- 1/3 and 2/3 bottle drawer kit for refrigerated counters PNC 881187
- Kit 4 wheels, h100mm (2 with brakes) for refrigerated counters PNC 881191
- Kit 4 wheels, h150mm (2 with brakes) for 2&3 compartment refrigerated counters PNC 881193
- Lock for refrigerator/freezer counters with 3 compartments - h650mm PNC 881246

Sustainability

- Removable triple-chamber balloon magnetic gasket to improve insulation and reduce energy consumption and ease of cleaning.
 - CFC and HCFC free, highly ecological refrigerant type: R290 (ecological gas in foam: cyclopentane). Hydrocarbon refrigerant gas R290 for the lowest environmental impact (GWP=3), to reduce green house and ozone depletion effects.
 - CFC and HCFC free (highly ecological refrigerant type: R290).
 - IQ Defrost - fully automatic defrost starts only when ice is actually building-up in the evaporator and adapts the defrosting duration to guarantee perfect ice removal while optimizing



CRIO Line CP
1 Door and 6 Drawer Refrigerated Counter, 420lt with Splashback (R290)

The company reserves the right to make modifications to the products without prior notice. All information correct at time of printing.

Front

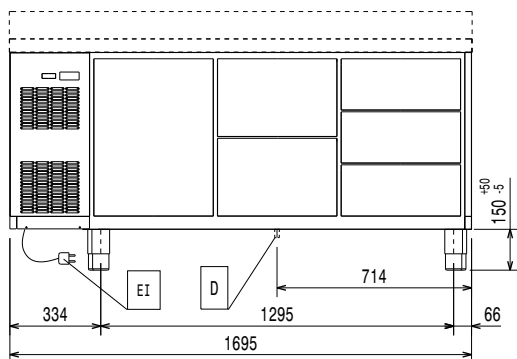

Side

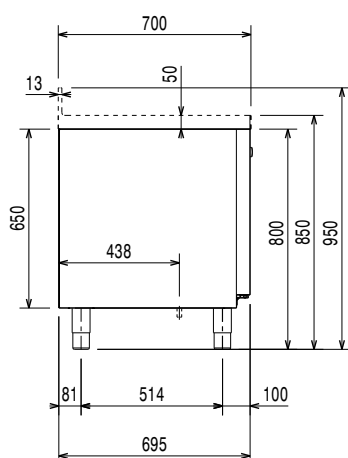

EI = Electrical inlet (power)

Top

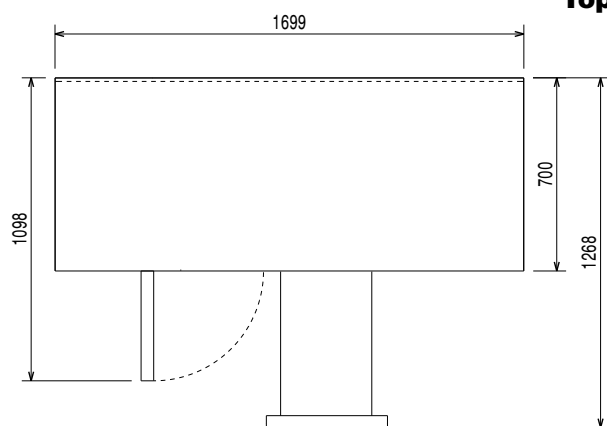

Electric

Supply voltage:	721148 (AA3R3ACC)	220-240 V/1 ph/50 Hz
Electrical power max.:		0.22 kW
Defrost Power:		0.2 kW
Plug type:		CE-SCHUKO

Key Information:

Gross capacity:		
Net Volume:		159.4 lt
Door hinges:		Left Side
External dimensions, Width:		1699 mm
External dimensions, Depth:		700 mm
External dimensions, Height:		950 mm
Internal Dimensions, Width:		1252 mm
Internal Dimensions, Depth:		560 mm
Internal Dimensions, Height:		510 mm
Net weight:		118 kg
Shipping volume:		1.57 m ³
Depth with doors open:		1110 mm
Height adjustment:		-5/50 mm

Refrigeration Data

Control type:	Digital
Compressor power:	0.25 hp
Refrigeration power at evaporation temperature:	-10 °C
Min/Max internal humidity:	40/85
Operating temperature min.:	-2 °C
Operating temperature max.:	10 °C
Operating mode:	Ventilated

Sustainability

Current consumption:	1.6 Amps
Energy Class (EU Reg. 2015/1094):	B
Yearly and daily energy consumption (EU Reg. 2015/1094):	700kWh/year - 2kWh/24h
Climate class (EU Reg. 2015/1094):	Normal duty (cl.4)
Energy Efficiency Index-EEI (EU Reg. 2015/1094):	31,86
Refrigerant type:	R290
GWP Index:	3
Refrigeration power:	358 W
Refrigerant weight:	65 g

ALPENINOX

CRIO Line CP 1 Door and 6 Drawer Refrigerated Counter, 420lt with Splashback (R290)



EU energy labelling from 1st July 2016

The European energy labelling scheme for professional refrigerators and freezers is based on requirements setting Minimum Energy Performance standards for commercial refrigeration cabinets sold within the EU. These requirements are designed to drive energy efficiency and environmentally friendly approach for professionals. The European energy labelling scheme will apply to all manufacturers and importers who sell and market products within the EU and it is mandatory across Europe. Important: all products which consume energy above the minimum level will not be able to be sold within the EU from 1 July 2016.

SI 2020 No. 1528.

Important: all products which consume energy above the minimum level will not be able to be sold within the EU from 1 July 2016.



CRIO Line CP
1 Door and 6 Drawer Refrigerated Counter, 420lt with Splashback (R290)

The company reserves the right to make modifications to the products without prior notice. All information correct at time of printing.

2023.12.06

EU energy labelling from 1st July 2016

The European energy labelling scheme for professional refrigerators and freezers is based on requirements setting Minimum Energy Performance standards for commercial refrigeration cabinets sold within the EU. These requirements are designed to drive energy efficiency and environmentally friendly approach for professionals. The European energy labelling scheme will apply to all manufacturers and importers who sell and market products within the EU and it is mandatory across Europe. Important: all products which consume energy above the minimum level will not be able to be sold within the EU from 1 July 2016.

SI 2020 No. 1528.

Important: all products which consume energy above the minimum level will not be able to be sold within the EU from 1 July 2016.

